

Injectronics

Remanufactured Automotive Electronics Components

TECHNICAL BULLETIN

Document number: T0071

For further technical information regarding testing, repairs or to search for New or Remanufactured Automotive electronic products, please visit www.injectronics.com.au, call our office on (+613) 8792 6999, or email sales@injectronics.com.au

Make: Holden

Model: Commodore VN/VP V6

Subject: Crank angle sensor

Even though V6 Commodores were introduced as early as 1988 (VN) Injectronics still receive countless phone calls regarding the operation and diagnosis of the timing case mounted crank angle sensor.

The sensor is hall-effect in operation and consists of a central magnet with two hall sensors mounted either side of the magnet. It is situated in behind the crank shaft pulley at the front of the engine. Connected to the back of the crank shaft pulley are two sets of interceptor vanes. One set consists of 18 vanes and windows (18 x Signal / Crankshaft revolution) and the other consists of 3 vanes and windows (3 x signal / crankshaft revolution). The 18 vanes and windows are all of equal size and therefore represent 10° of crankshaft rotation.

The 3 vanes and windows are NOT of equal size as each window is progressively larger. The first window represents 10° of crankshaft rotation, the second represents 20° and the third represents 30° of crankshaft rotation. The positioning of the two interceptor rings in relation to each other is critical and any damage to either set can be detrimental to engine operation.

The 3x and 18x signals (zero to 5) are produced by the crank angle sensor are used by the DFI module to determine crankshaft position for the ignition system so as to trigger the correct ignition coil. The DFI module also uses these signals to generate the crankshaft reference signal which the ECM requires before allowing injection pulses also for RPM and EST calculations.

It is important to note that the crankshaft reference signal is derived by an internal divide by six circuit within the DFI module which divided the 18x signal by six.

The divider circuit is only enabled after the DFI module receives the 3x signals. Once enabled, the 3x signal is no longer required and the engine would run without it if the signal is lost for whatever reason. If the engine was turned off however, and an attempt was made to restart the engine there would be no injection pulse until the 3x signal was restored.

To check the 3x signal, 18x signal and crankshaft reference signal, the following patterns should be observed on an oscilloscope.

T0071.doc

This publication is distributed with the understanding that the authors, editors and publishers are not responsible for the results of any actions or works of whatsoever kind undertaken on the basis of information contained in this publication, nor for any errors or omissions contained herein. The publishers, authors and editors expressly disclaim all and any liability to any person whomsoever whether a purchaser of this publication or not in respect of anything and of the consequences of anything done or omitted to be done by any such persons in reliance, whether whole or partial upon the whole or any part of the contents of this publication. Injectronics Australia Pty Ltd. © Copyright 2001.

Injectronics

Remanufactured Automotive Electronics Components

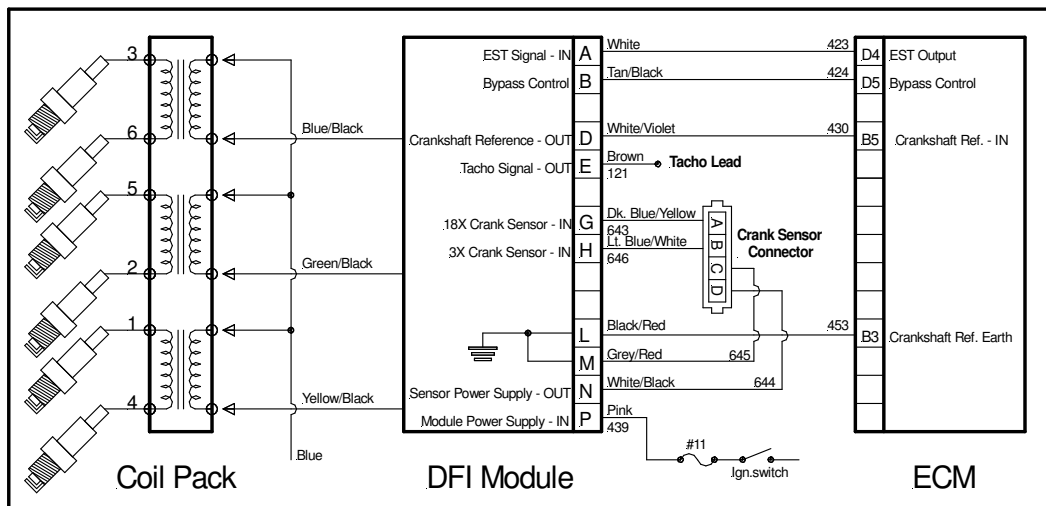
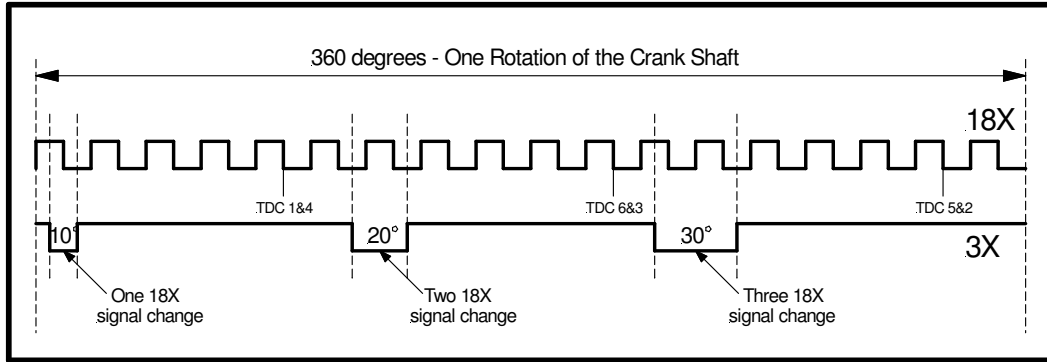

T0071.doc

This publication is distributed with the understanding that the authors, editors and publishers are not responsible for the results of any actions or works of whatsoever kind undertaken on the basis of information contained in this publication, nor for any errors or omissions contained herein. The publishers, authors and editors expressly disclaim all and any liability to any person whomsoever whether a purchaser of this publication or not in respect of anything and of the consequences of anything done or omitted to be done by any such persons in reliance, whether whole or partial upon the whole or any part of the contents of this publication. Injctronics Australia Pty Ltd. © Copyright 2001.